

Morgana Systems Ltd  
3909 Upland Way, Marietta  
GA 30066 Georgia  
USA

Tel: 866 463 5060  
Fax: 770 565 6163

www.morganausa.com  
morganausa@comcast.net



# ElectroCreaser 36/52

Quality blade and matrix creasing, with a price and performance geared to the needs of the smaller or inplant printer.



The semi-automatic ElectroCreaser is the ideal unit for printers who need something faster than a manual creaser - such as the Morgana DocuCrease - but do not have the volume of work to justify a fully automated machine like the Morgana AutoCreaser.

## Creasing versus Scoring.

Traditional rotary scoring machines use circular blades that are in constant motion as the stock passes through them. This creates a ploughing action that actually cuts through the top fibres of the paper or card in order to create a score. Inevitably this weakens the paper and encourages cracking. In contrast, the Morgana DocuCrease employs a unique creasing rule and matrix as illustrated overleaf, that eliminates tearing and, therefore, cracking.

## Key Product Features

- **Fast & easy to setup**
- **Semi-automatic**
- **Foot switch operation**
- **Takes stock up to 0.015" (approx 150lb cover)\***
- **Rule and matrix guaranteed for life**
- **Heavy duty**
- **36cm or 52cm sizes**
- **Crease without cracking**

Made in the UK, the ElectroCreaser is ideal for the smaller printer or inplant. A compact, table-top unit, it is fast to set up and simplicity itself to operate.

Like other Morgana products, it employs a blade and matrix action which, unlike scoring, will not cause any damage to the substrate, and will produce a superb crease on stocks up to 0.4mm (approx 400 gsm)\* including laminated material.

Unlike scoring, which can damage card or paper, the Morgana blade and matrix method ensures a clean sharp fold without damage to the substrate.

It provides 2 creasing widths as standard, 0.04" and 0.06" - with the ability to change from one to another in seconds. It also has a special "Super Speed" stop system, which greatly simplifies jobs that call for multiple creases.

The creasing matrix is electronically activated by a foot switch for increased accuracy and productivity.

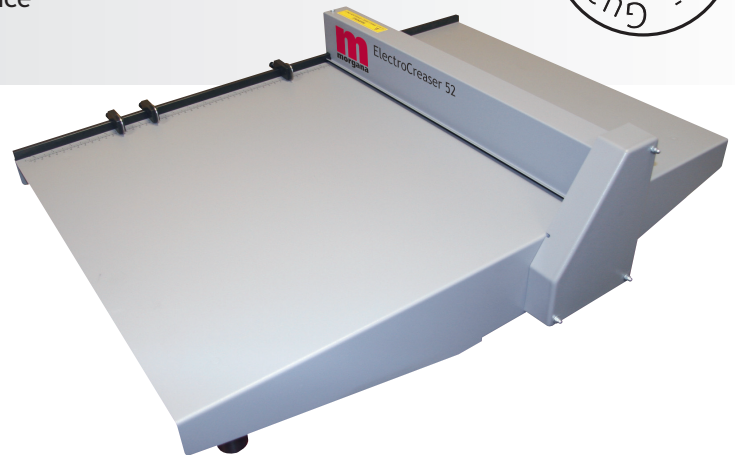

# ElectroCreaser 36/52

Quality blade and matrix creasing, with a price and performance geared to the needs of the smaller or inplant printer.

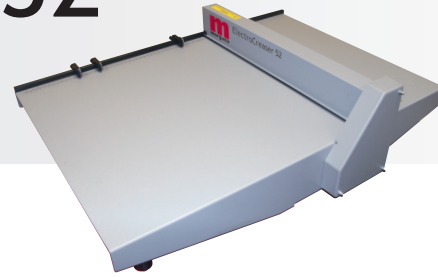

## technical specifications

### ElectroCreaser 36

Maximum crease (to backstop)	L 17" x W 14.3"
Minimum crease (to backstop)	L 1.18"
Maximum paper thickness	0.015" (approx 150lb cover)* including laminated material
Minimum paper thickness	0.004" (approx 20lb bond)*
Dimensions	L 27.5" x W 18.8" x H 8.26"
Weight	39 lb
Power requirement	240/115v 50/60hz

### ElectroCreaser 52

Maximum crease (to backstop)	L 20" x W 20"
Minimum crease (to backstop)	L 1.18"
Maximum paper thickness	0.015" (approx 150lb cover)* including laminated material
Minimum paper thickness	0.004" (approx 20lb bond)*
Dimensions	L 30.7" x W 25" x H 8.6"
Weight	60.6 lb
Power requirement	240/115v 50/60hz

Note: the production speed varies according to material size and the number of creases on the sheet

**Creasing rule and matrix.** The ElectroCreaser uses an identical mechanism to that on the more expensive Pro range and is guaranteed for life. With thousands of these mechanisms installed throughout the world our creasing technology is unparalleled in both performance and longevity.

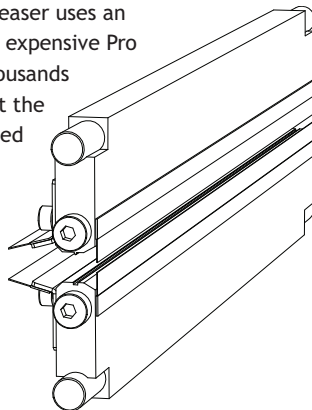

**\*Disclaimer**

As part of our continued product improvement plan, specifications and information published here are subject to change without notice. All specifications are dependent on application, type of stock, temperature, RH and print engine used. Specifications quoted were measured on uncoated and unprinted stock. E & OE.